



PUMPS AUSTRALIA

BETTER • FASTER • EASIER



UNDERSINK PUMP SYSTEMS

EXPLODED VIEW &
INSTRUCTION MANUAL

MODELS: RUP160 | RUP160-T | RUP230 | RUP230-T
CODE: 11911 | 11997 | 13519 | 12208

COMPONENTS & MATERIALS

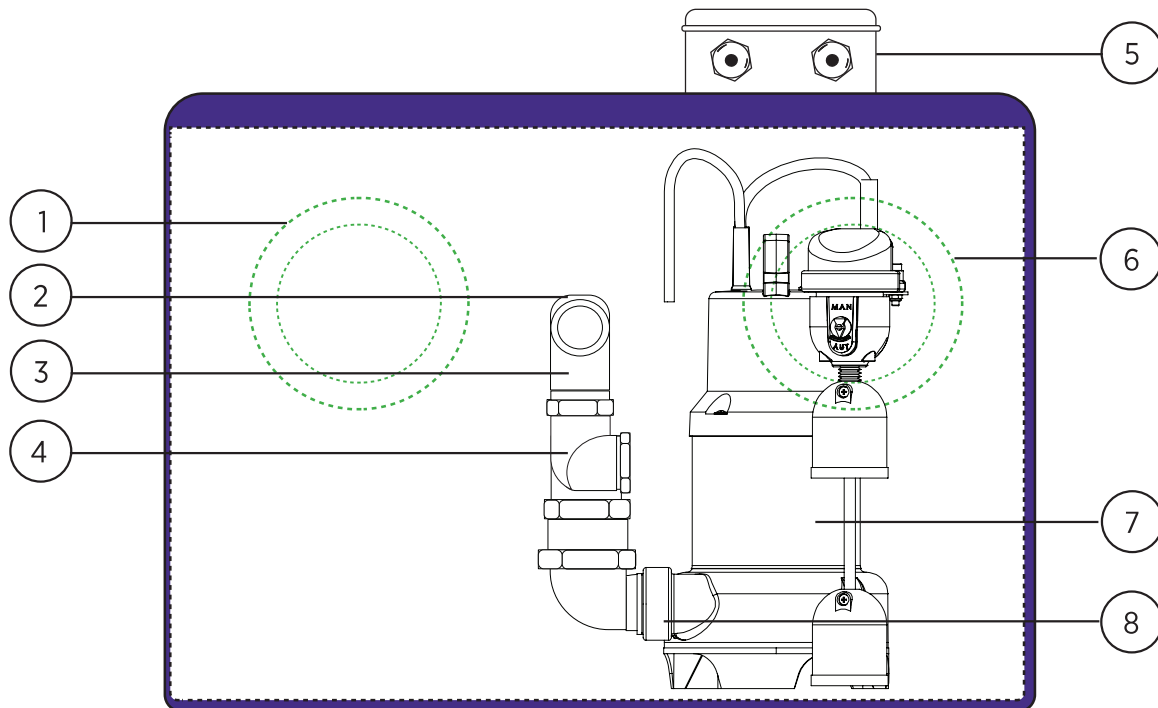

RUP UNDERSINK SYSTEMS

POSITION	COMPONENT	MATERIAL
1	50mm Connection for Optional Vent (Cap if vent not required)	Poly
2	25mm Elbow	Poly
3	25mm Discharge Pipework	Poly
4	25mm Swing Check Non-Return Valve	Brass
5	Pump Timer on RUP160-T and RUP230-T only	Poly
6	50mm Connection for Inlet	Poly
7	REEFE® RVE160VF/RVE230VF Sump Pump with Vertical Float	Technopolymer/Stainless steel
8	25mm Barrel Union	Nickel Coated Brass

PARTS LIST & EXPLODED VIEW

PUMP ONLY

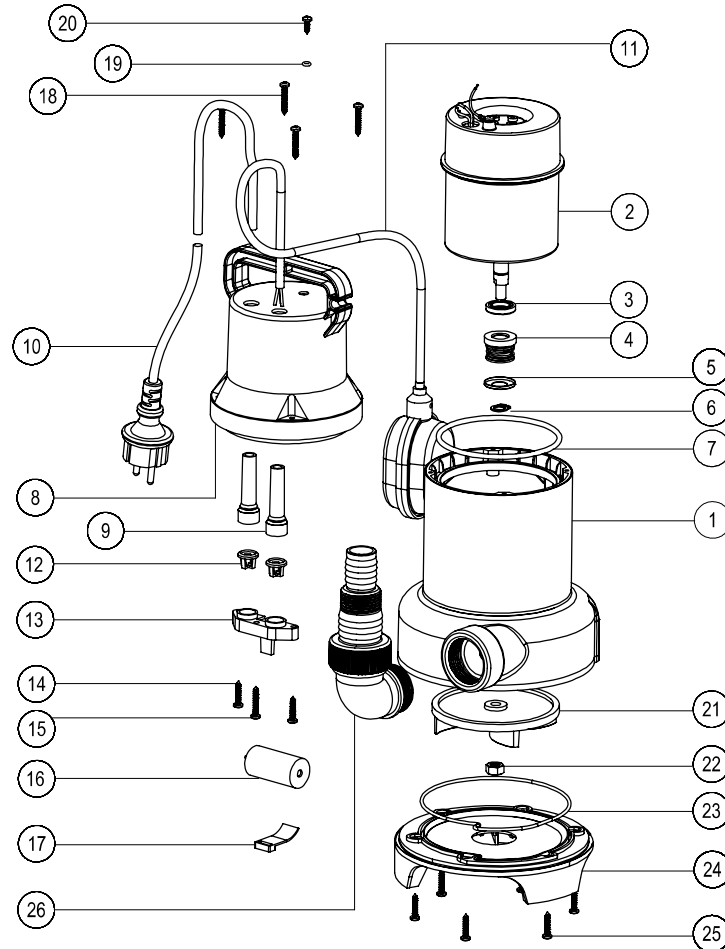

RUP UNDERSINK SYSTEMS

POSITION	COMPONENT	POSITION	COMPONENT
1	Pump Body	14	Cable Gland Screw (2)
2	Motor	15	Cable Gland Screw (3)
3	Mechanical Seal (1)	16	Capacitor
4	Mechanical Seal (2)	17	Capacitor Clamp
5	Mechanical Seal (3)	18	Screw (For Vertical Float)
6	Shaft Ring	19	O-ring
7	O-ring	20	Pump Head Screw
8	Pump Head	21	Impeller
9	Cable Gland	22	Shaft Nut
10	Power Cable	23	Sealing O-Ring
11	Float Switch	24	Pump Base
12	Cable Gland Screw (1)	25	Base Screw
13	Cable Gland Bracket	26	Discharge Connection Elbow

WARRANTY | INSTRUCTION MANUAL

IMPORTANT NOTE: This unit MUST NOT be used for RAW SEWAGE. Use with RAW SEWAGE will VOID the warranty.

OPERATION

This unit is designed to be connected to a sink or similar, and to lift the grey water up to an existing sewer line, where the supplying fixtures are located below the sewer line.

INSTALLATION

ALL INSTALLATIONS must comply with all applicable PLUMBING REGULATIONS, COUNCIL/SHIRE BY-LAWS and REGULATIONS. It is the installers and owners responsibility to ensure the product and installation is compliant.

Warranty does not cover improper use or improper installation.

POWER SUPPLY: This unit is supplied with a 10amp 3-pin Australian plug.

This unit is only compatible with basins/sinks. IT MUST NOT BE USED FOR RAW SEWAGE.

The decline of horizontal pipework must be at least one centimetre per metre.

RECOMMENDATION: It is recommended for the REEFE® Undersink Pump Station to be vented, either by connecting it to existing pump vent, or alternatively, by installing an air remittance valve connection to the vent connection. Ensure the air remittance valve is installed in the upright position.

SAFETY ADVICE

This device is not suitable for use by persons (including children) with limited mental, sensory or physical abilities or by persons without experience or knowledge about using this device.

Children are not aware of the danger of electrical devices. Please ensure that they do not play with this item.

SPECIFICATIONS

MODEL	RUP160	RUP230
CODE	11911	13519
PUMP	RVS160VF	RVS230VF
WATTAGE (P1, P2)	P1 - 650W P2-500	P1 - 650W P2-500
VOLTAGE	240V	240V
AMP	2.8A	2.9A
MAX HEAD	7m	8.4m
MAX FLOW	160L/Min	230L/Min
MAX TEMP	40C	40C
PUMP WEIGHT	5kg	5kg

USAGE

To ensure the trouble-free use of this unit, do NOT use this product for RAW SEWAGE – this will VOID the warranty.

If the appliance becomes blocked/jammed up with hair or other solids, this is the user’s responsibility to clear the blockage. It is NOT a warranty fault; it is user maintenance.

Please contact your plumber if your appliance is blocked or jammed, or is not working.

12 MONTH WARRANTY CONDITIONS - REEFE UNDERSINK PUMP STATIONS

1. Our goods come with guarantees that cannot be excluded under the Australian Consumer Law. If you are a consumer as defined by the Australian Consumer Law, you are entitled to a replacement or refund for a major failure and for compensation for any other reasonably foreseeable loss or damage. You are also entitled to have the goods repaired or replaced if the goods fail to be of acceptable quality and the failure does not amount to a major failure. If you (the purchaser) do not fall within the meaning of 'consumer' in the Australian Consumer Law the provisions of the Australian Consumer Law will not apply to you. The following conditions form part of the instructions and do not over-ride your statutory rights.
2. This warranty covers failure due to manufacturing defects for REEFE™ Compact Lifting Stations purchased and used in mainland Australia. We shall repair or replace faulty goods when we ascertain that the fault is due to manufacturing defects, within 12 months of the original date of purchase. If you require a refund, you must return the item to the original place of purchase.
3. Faults or losses or failure caused due to: Accidents, blockages, misuse, lack of maintenance, improper installation, incorrect application, not following installation instructions, installation that does not conform to the applicable Plumbing Standards and/or Council or Shire By-laws and regulations, damage caused by lightning strike/power surges/spikes/brownouts/operating the appliance on power other than 230-240 volts 50Hz mains power/operating the pump on power supplied by a domestic generator -are not covered by warranty.
4. Where fitted: The complete Impeller set (including shaft), Seals, Mechanical Seals, and O-rings are all wearing items and therefore are not covered for "normal wear and tear". They are covered by this warranty if they are faulty due to a manufacturing defect.
5. Warranty is void if any tampering or removal of identification labels or electrical cables has occurred, or any non-genuine parts have been fitted, or repairs have been carried out by unqualified persons. No warranty applies for REEFE COMPACT LIFTING STATIONS sold or used for HIRE or RENT or LEASE or MINE SITES or REMOTE AREAS or INDUSTRIAL APPLICATIONS or SCHOOLS or PUBLIC VENUES, all of which are defined by us, at our discretion.
6. The Warranty excludes accidental or deliberate blockages, accidental or deliberate breakages, normal wear and tear, fading or breakdown due to the effect of exposure to sunlight or chemicals or any other external factor that may affect the life of the product. All Blockages are a maintenance event, clearing blockages or pumps seized due to foreign objects, is not covered by warranty.
7. Models RCLS and RCLS-M, are guaranteed as fit for the purpose of pumping **GREY WATER ONLY** in normal domestic household use, and for **NO OTHER USE**. **Warranty is VOIDED if used for pumping RAW SEWAGE.**
8. Performance data quoted is generally from test data and is approximate and does not take into account factors in the installation such as loss of pressure and flow due to pipework & pipe-fittings & valves. It is the purchaser's responsibility to ensure that the product is fit for their purpose and of sufficient size & performance for their application.
9. IMPORTANT: No electrical appliances last forever. Therefore, ALL installations must be constructed to allow the owner to easily remove the appliance for servicing, replacement, warranty replacement or upgrading. Warranty is void if the unit cannot be EASILY removed for service. Warranty replacement does not normally include costs of removal and re-installation as we have no control over the method of installation. Warranty is void if no swing check-valve is fitted to all inlets and the outlet of the appliance. A swing check-valve is required to avoid backflow.
10. Before installing or servicing disconnect from the power supply
11. This appliance **MUST NOT** be installed in any manner that if it were to leak, or fail to work, that it would cause damage or loss to property or persons. It **MUST** be installed in a well-ventilated and drained area. All warranty is void if this condition is not heeded and no liability can be accepted in the case of damage or loss caused by failing to comply with this condition.
12. The appliance must be correctly earthed and connected to a power circuit that is protected by an RCD (safety switch).
13. In the case of a fault, refer to the Trouble Shooting Guide first. If these steps do not rectify the problem, then return the faulty appliance to the original place of purchase with proof of purchase for replacement or refund. Alternatively you can mail us at PO BOX 650 MORNINGSIDE QLD 4170 or send an email to csv@ascento.com.au with a photo of the faulty item, copy of your purchase receipt, a description of the problem, and your name and address and phone number - we will review your request and send you a replacement directly if we accept your warranty claim. Or call us on 1800 807 604 with the above information; however, we will always require a copy of your purchase receipt. Do not send the product to us unless we ask you to do so.
14. If an exact replacement is not available, the closest equivalent product will be supplied at our discretion.
15. This warranty does not exclude any non-excludable rights according to Australian Law. However, any condition that is made void by Australian Law does not void the remaining conditions, which shall stand unaltered.